



Roll-In & Roll-Thru Refrigerator and Freezer Models Installation, Operation and Troubleshooting Manual



Manual Part No. 50707412

Rev. 00

Print Date: 04/16/12

110 Woodcrest Road, Cherry Hill, NJ 08003

Phone: (856) 428-4200 Fax: (856) 673-0038 Website: www.victoryrefrigeration.com

E-Mail: parts@victoryrefrigeration.com order-entry@victoryrefrigeration.com service@victoryrefrigeration.com

THANK YOU

Thank you for purchasing a Victory ULTRASPEC™ Series cabinet! This unit has passed our strict Quality Control Inspection and meets the high standards set by Victory Refrigeration. You have made a quality investment that with proper maintenance will give you many years of service.

Please read the following installation and maintenance instructions before installing or using your unit. If you have any questions, please call our Technical Service Department at (800) 523-5008.

IMPORTANT INFORMATION - PLEASE READ

- * Please read these instructions carefully before installing or using. If recommended procedures are not followed, warranty claims may be denied.
- * Your Warranty Registration information is located on the next page of this manual. Please complete the card and submit it to Victory Refrigeration within 10 days of installation. Failure to properly register equipment may limit or void the warranty.
- * Victory Refrigeration reserves the right to change specifications and product design without notice. Such revisions do not entitle the buyer to corresponding changes, improvements, additions or replacements for previously purchased equipment.

LIMITED WARRANTY

(Continental USA Only)

The Seller warrants to the original purchaser, equipment manufactured by Seller to be free from defects in material and workmanship for which it is responsible. The Seller's obligation under this warranty shall be limited to replacing or repairing at Seller's option, without charge, F.O.B. Seller's factory, any part found to be defective and any labor and material expense incurred by Seller in repairing or replacing such part, such warranty to be limited to a period of twelve (12) months from the date of installation, provided, however, installation occurs within three (3) months of date of purchase and equipment is in normal use and service and is installed in accordance with manufacturer's recommendations and provided terms of payment have been fully met. All labor shall be performed during regular working hours. Overtime premium charges will be at Buyer's expense.

Proof of purchase must be supplied to Seller to validate warranty. This warranty is valid only if equipment is properly installed, started-up and inspected by the dealer or authorized Victory Service agent.

Removal or alteration of the serial/data plate from any equipment shall be deemed to release Seller from all warranty obligations or any other obligations, expressed or implied.

This warranty does not cover Thermostat, Controller, Thermometer or Defrost Timer calibration and/or adjustment, freight damage, normal maintenance items outlined in Owner's Manual, adjustment of door mechanisms or replacement of door gaskets, light bulbs, fuses or batteries. The warranty does not cover installation, start-up, normal maintenance, food loss, or other consequential damage.

Any repairs or replacement of defective parts shall be performed by Seller's authorized service personnel. Seller shall not be responsible for any costs incurred if the work is performed by other than Seller's authorized service personnel. Reimbursement claims for part(s) or labor service costs must be made in writing. Model, cabinet serial numbers and installation location must be shown on the claim. A receipted bill from the servicing agency must accompany the claim, together with full details of the service problems, diagnosis and work performed. Victory will determine at its sole discretion whether further documentation on a claim is to be submitted.

Seller shall not be liable for consequential damages of any kind which occur during the course of installation of equipment, or which result from the use or misuse by Buyer, its employees or others of the equipment supplied hereunder, and Buyer's sole and exclusive remedy against Seller for any breach of the foregoing warranty or otherwise shall be for the repair or replacement of the equipment or parts thereof affected by such breach.

The foregoing warranty shall be valid and binding upon Seller if and only if Buyer loads, operates and maintains the equipment supplied hereunder in accordance with the instruction manual provided to Buyer. Seller does not guarantee the process of manufacture by Buyer or the quality of product to be produced by the equipment supplied hereunder and Seller shall not be liable for any prospective or lost product or profits of Buyer.

THE FOREGOING WARRANTY IS EXCLUSIVE AND IN LIEU OF ALL OTHER EXPRESS AND IMPLIED WARRANTIES WHATSOEVER. SPECIFICALLY THERE ARE NO IMPLIED WARRANTIES OF MERCHANTABILITY OR OF FITNESS FOR A PARTICULAR PURPOSE.

The foregoing shall be Seller's sole and exclusive obligation and Buyer's sole and exclusive remedy for any action, whether in breach of contract or negligence. In no event shall Seller be liable for a sum in excess of the purchase price of the item.

You may fax this completed page to (856) 673-0038, or copy and mail the form below to Victory.

NOTE: The mail-in or faxed form must be filled out and forwarded to Victory by the installer or customer within 10 days after start-up. Failure to do this may invalidate the warranties. Retain this information for your records.



110 WOODCREST ROAD
CHERRY HILL, NJ 08003-3648
TEL: (856) 428-4200 : FAX: (856) 673-0038

Cabinet Model No. _____

Cabinet Serial No. _____

(Data plate information located inside cabinet on the upper left wall)

**WARRANTIES NOT VALID UNLESS REGISTERED AT
FACTORY WITHIN 10 DAYS AFTER START-UP DATE.**

ORIGINAL DATE OF INSTALLATION _____

CUSTOMER NAME _____ PHONE _____

STREET _____ CITY _____ STATE _____ ZIP CODE _____

DEALER'S NAME _____ PHONE _____

STREET _____ CITY _____ STATE _____ ZIP CODE _____

Glossary of Common Terms & Descriptions

C

Compressor - The compressor is the heart of the system. The compressor does just what its name states. It compresses the low pressure refrigerant vapor from the evaporator and compresses it into a high pressure vapor.

The inlet to the compressor is called the "Suction Line". It brings the low pressure vapor into the compressor.

After the compressor compresses the refrigerant into a high pressure Vapor, it removes it to the outlet called the "Discharge Line".

Condenser Coil - The "Discharge Line" leaves the compressor and runs to the inlet of the condenser coil located on top of the cabinet. Because the refrigerant is compressed, it is a hot high pressure vapor (as pressure goes up – temperature goes up). The hot vapor enters the condenser coil and starts to flow through the tubes. Cool air is blown across the outside of the finned tubes of the condenser coil (usually by a fan or water with a pump).

Since air is cooler than the refrigerant, heat jumps from the tubing to the cooler air (energy goes from hot to cold – "latent heat"). As the heat is removed from the refrigerant, it reaches its "saturated temperature" and starts to "flash" (change states), into a high pressure liquid.

The high pressure liquid leaves the condenser coil through the "liquid line" and travels to the "metering device". Sometimes running through a filter dryer first, to remove any dirt or foreign particles.

D

Defrost - The term is used to identify the function of a refrigerator or freezer to remove frost or ice from the internal evaporator coil.

Differential - An increment in a given function, expressed as the product of the derivative of that function and the corresponding increment in the independent variable

An example of "differential" is below.

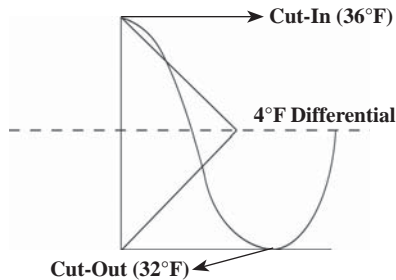

E

Energy Saving Mode - A mode automatically activated during periods when the kitchen is not operating. After four (4) hours of no door openings, the cabinet will revert to the energy saving mode.

F

FLEXTEMP Mode (*optional feature) - This option provides the ability to select a unique refrigerator temperature from 28°F to 40°F for multipurpose applications.

H

HACCP Functions - The V-TEMP™ controller records all critical temperature events including the date and time when the alarms occurred.

M

Manager's Lockout Feature - This feature prevents unauthorized employees from changing programmed settings on the control panel.

S

Setpoint - This is the refrigerator or freezer cut out temperature set by the operator. Prior to shipping, refrigerators are factory preset at 35°F and freezers are factory preset at -2°F.

SUPERCOOL Mode - When initiated, this feature provides a "constant on" refrigeration condition for when food has just been loaded into a refrigerator and needs to be quickly brought down to a safe temperature protecting costly food investment and extending product shelf life.

Table of Contents

RECEIVING, UNCRATING & INSTALLATION

Receiving.....	1
Uncrating.....	1
Roll-In or Roll-Thru Refrigerator/Freezer Location.....	1
Roll-In or Roll-Thru Refrigerator/Freezer Installation.....	1-2
Cabinet Cleaning.....	2
Electric Supply.....	2
Controller.....	2
Installation Checklist.....	2

V-TEMP™ ELECTRONIC CONTROLLER

LED Indicators & Alarms.....	3
Keypad & Associated Functions.....	3-5
Alarm Codes, Descriptions & Resolution(s).....	5
Error Codes.....	5
User Parameters.....	6-7

PERIODIC CLEANING

Cabinet Cleaning.....	8
Condenser Maintenance.....	8
Lubrication.....	9
Installing Replacement Door Gasket.....	9

TROUBLESHOOTING GUIDE FOR COMMON PROBLEMS

Common Problems & Remedies.....	10
---------------------------------	----

WIRING DIAGRAMS

1, 2 & 3 Section Refrigerator 115 Volt/15 Amp & 20 Amp.....	11
1, 2 & 3 Section Refrigerator 115 Volt/208-230 Volt Condensing Unit.....	11
1 & 2 Section Freezer 115 Volt/15 Amp & 20 Amp.....	12
3 Section Freezer 115 Volt/208-230 Volt Condensing Unit.....	12

RECEIVING, UNCRATING & INSTALLATION INSTRUCTIONS

Proper installation is the first step to operation. We recommend that your refrigerator or freezer be installed by a Victory authorized service technician.

Receiving

Prior to shipping, all Victory products are factory tested for performance and thoroughly inspected to ensure they are free of any defects. Upon receipt, carefully examine the unit for any damage that may have occurred during shipping and delivery. Any damage, discrepancies, shortages or overages should be noted on the carrier's **Bill of Lading** and a freight claim must be filed immediately with the carrier. If damage is noticed after receipt, contact the carrier's local terminal and file a freight claim. In either case, it is important that all original cartons, crates and interior packaging material are saved until inspection has been made with the delivering carrier.

Uncrating

WARNING: *Never lay your refrigerator or freezer down on either its back, front or sides. This causes compressor oil to enter the refrigerant lines which can damage the compressor at start-up. If the unit is laid down, it must be set upright for a minimum of 24 hours before starting the compressor. Failure to adhere to the above recommendation will void the warranty.*

Tools Needed: 3/4" Box Wrench, Adjustable Wrench, Level, Flathead Screwdriver, Box Cutting (or Carpenter) Knife

1. Take off the cardboard top capping by removing all clear tape and staples with a flathead screwdriver. Also remove all staples at the bottom of the cardboard carton and skid.
2. Starting from the top of the cardboard carton, carefully take a box cutting knife and try to make one continuous cut until you come to the wooden skid. Remove the cardboard carton from around the cabinet and discard.

***Note:** *An additional clear, plastic, protective wrap is applied directly to the exterior of all cabinets with glass doors.*

3. Move cabinet as close to final location as possible before removing skid.
4. Remove the shipping skid by tipping the cabinet forward. Remove the shipping bolts with 3/4" box wrench while the cabinet is held in one direction. Repeat this procedure while the cabinet is held in the opposite direction.

WARNING: *The cabinet must be blocked and secured when removing the shipping skid.*

5. Remove protective vinyl coating from all interior and exterior surfaces.

Roll-In or Roll-Thru Refrigerator/Freezer Location

Consider the following when selecting a location for your refrigerator or freezer:

1. **Clearance** - There must be a minimum clearance of 12" between the top of the refrigerator or freezer and the ceiling.
2. **Floor Load** - The floor on which the cabinet will rest must be even/level, free of vibration and strong enough to support the combined weights of the cabinet plus the maximum product load.
3. **Ventilation** - The air cooled, self-contained refrigerator or freezer requires a sufficient amount of cool, clean air. Avoid placing the refrigerator or freezer near heat generating equipment such as ovens, ranges, heaters, fryers, steam kettles, etc., and out of direct sunlight. Avoid locating the self-contained refrigerator or freezer in an unheated room, or where the room temperature may be below 55°F.

Roll-In or Roll-Thru Refrigerator/Freezer Installation

***IMPORTANT:** The floor where the new roll-in/roll-thru cabinet is to be permanently located must be a level, flat surface prior to installation. Failure to properly level and install your equipment can void equipment warranty!

***Notes:** (a) *If it is necessary to move the roll-in/roll-thru cabinet after taking off the skid, remove all doors and carefully push the cabinet at a point of no more than 36" (inches) from the bottom to avoid damage.*

(b) *It is an NSF requirement that roll-in/roll-thru models are sealed to the floor upon installation.*

(c) *If required, the procedure for setting and grouting the two section model is within this section and also applies to one and three section models. For reasons of clarity, the illustrations are shown without doors on page 2.*

Step 1: Locate roll-in/roll-thru model in exact position in which it is to be permanently set.

Step 2: Level unit, inserting metal shims under unit where required. It is important that an accurate carpenter's level be used when leveling cabinet. See **Figure 1** on next page.

Step 3: Construct a wood form to act as a retainer for the grouting compound around the entire base of the cabinet. See **Figure 2** below. Pour the grout mixture at various intervals around the form to assure complete fill under the cabinet.

Step 4: Using a wide blade putty knife, taper the grout to a feather edge.

Step 5: A tube of NSF approved silicone sealer, having an applicator type nozzle, is highly suited for sealing roll-in/roll-thru models to the floor. Cut off a small portion of the applicator nozzle and apply a small uniform bead completely around the base of the cabinet.

Step 6: Allow silicone to fully cure before using the roll-in/roll-thru cabinet.

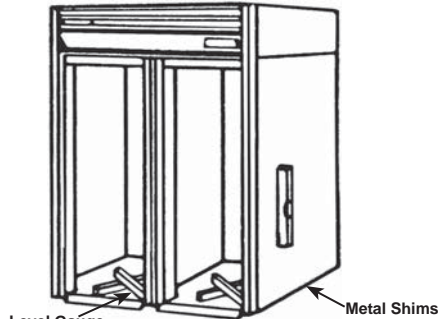

Figure 1

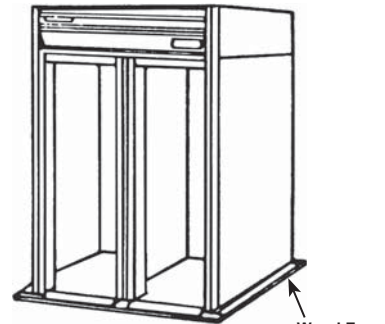

Figure 2

Cabinet Cleaning

Prior to use, the interior and exterior surfaces of the cabinet should be cleaned thoroughly with warm water, mild detergent and a soft cloth. Apply with a dampened cloth and wipe in the direction of the metal grain and allow to air dry with the door(s) open. **DO NOT** use chlorinated or abrasive cleansers, and only use a soft clean cloth.

Electric Supply

115 Volt self-contained units are provided with a 15 or 20 Amp power cord with plug that is shipped coiled on top of the cabinet. The power cord is equipped with a 3-prong (grounding) plug that is to be used in an appropriately rated and dedicated 3-prong (grounding) receptacle.

***NOTE:** Have a wall outlet checked by a qualified electrician for polarity and proper grounding prior to plugging in the power cord.

For units not provided with a power cord, the electrical connection should be made by a qualified electrician in accordance with local electrical codes. The electrical supply requirements are on the rating (or data) plate located on the left hand interior wall of the cabinet. Use of a dedicated circuit with separate grounding wire is required.

Controller

When first supplying power to the cabinet there will be approximately a one minute delay before the compressor and fan motors start to operate. Also, if power has been out for over 48 hours, a visible "rtc" (or Real Time Clock) error code will show in the display window. This indicates that the real time clock must be set. Please refer to page 4 "SETTING DATE AND TIME" section.

The controller can be set to maintain temperature between 32°F (0.0°C) to 44°F (6.6°C) for refrigerators, and -6°F (-21.1°C) to 15°F (-9.4°C) for freezers. Prior to shipping, refrigerators are factory preset at 35°F and freezers are factory preset at -2°F.

***NOTE:** Once the desired temperature "setpoint" has been chosen, there can be a +4 degree temperature difference shown within the controller display when the refrigerator cabinet is in operation, and +5 temperature difference for freezers. For example, a refrigerator controller "set point" is 32°F, but the refrigerator cabinet can operate between 32°F to 36°F.



V-TEMP™ Control Panel

Installation Checklist

After the cabinet has been installed, leveled and cleaned as described, refer to the following checklist prior to start-up.

- Check for proper electrical hook-up. Cabinet **must not share receptacle** with another piece of equipment.
- Check exposed refrigeration line connections for leaks. Make sure refrigeration lines are not dented, kinked or rubbing.
- Check condenser & evaporator fan(s) for freedom to rotate without striking any stationary members.
- Check that cabinet is level.

V-TEMP™ ELECTRONIC CONTROL

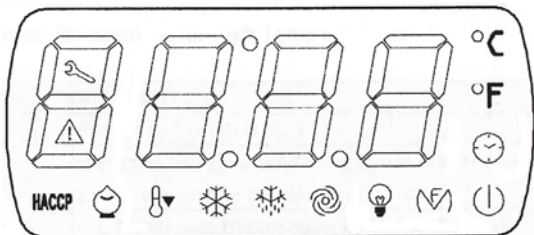

"LED Display Window"

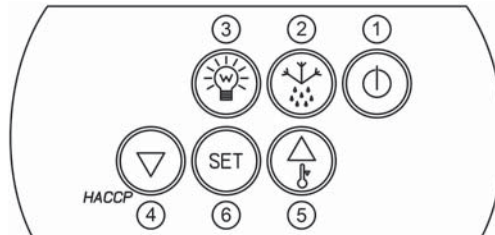

"V-TEMP™ Keypad"

LED	DESCRIPTIONS
	ON: The compressor is on FLASHING: (1) The working setpoint is being changed; (2) Compressor protection is in progress OFF: The compressor is off
	ON: Defrosting in progress FLASHING: (1) Defrosting requested, but compressor protection is in progress. (2) Dripping in progress
	ON: The evaporator fan is high speed OFF: The evaporator fan is low speed for a refrigerator, or off for a freezer
	ON: Light switched on manually FLASHING: Normal mode. Light switched on because of door opening. OFF: The light is off
	ON: "SUPERCool MODE" in progress
	ON: Alarm or error in progress
HACCP	ON: Not all of the information regarding HACCP alarms has been displayed FLASHING: At least one new alarm has been recorded OFF: All of the information regarding the HACCP alarms has been displayed or the list of alarms has been deleted
	ON: "ENERGY SAVING MODE" in progress
	ON: This is a reminder to clean the condenser coil. This will turn on after 2 months of run time. Clean condenser coil then reset compressor hours.
	ON: The temperature scale will be in degrees Fahrenheit
	ON: The temperature scale will be in degrees Celsius
	ON: The instrument is in stand-by mode
	FLASHING: The day and real time is in the process of being changed

Note: To clear the maintenance (or wrench) indicator, first clean the condenser coil. Then, the compressor hours must be set. Use diagram named "V-TEMP™ Keypad" illustration to follow these instructions.

- Press and hold the (4) "DOWN" button for 1 second. The display will show "rtc".
- Use the (4) "DOWN" button to scroll and select "rCH".
- Press and release the (6) "SET" button.
- Press the (5) "UP" button to scroll and select "149".
- Press and release the (6) "SET" button. "- - -" will flash on the display for a few seconds and the HACCP LED will go off and the control will resume normal operation.

KEYPAD BUTTONS & FUNCTIONS

KEYPAD BUTTONS

***Note:** Use "V-TEMP™ Keypad" illustration above to follow these instructions.

Button 1: ON/STANDBY

Press this button for a few seconds to switch the cabinet on and off.

Button 2: MANUAL DEFROSTING

Press this button for a few seconds to activate manual defrosting provided that the "SUPERCool MODE" is not already activated.

Button 3: CABINET LIGHT

This button is used for the glass door option. Press this button to switch the light on and off manually.

Button 4: DOWN BUTTON

This button scrolls through the menu items and decreases values. If this button is pressed for a few seconds, this will bring you to the menu. Use the "UP" and "DOWN" buttons to scroll through the options in the menu which are:

- LS:** List of HACCP Alarms
- rLS:** Reset HACCP Alarms
- CH:** Compressor Hours
- rCH:** Reset Compressor Hours
- rtc:** Real Time Clock

Button 5: UP BUTTON

This button scrolls the menu items and increases values. When pressed for a few seconds, the "SUPERCool MODE" is activated unless a defrosting or drip off mode is in progress.

During "SUPERCool MODE", the compressor will run constantly for one hour (adjustable with parameters). If the cabinet temp decreases by 10°F refrigerator or 15°F freezer, the "SUPERCool MODE" will then cycle with this new set point for the duration of the "SUPERCool MODE".

Button 6: SETPOINT

This provides access to the set point edit function.

KEYPAD FUNCTIONS

***Note:** Use "V-TEMP™ Keypad" illustration above to follow these instructions.

KEYPAD LOCKING & UNLOCKING (*Manager's Lockout Feature)

- The keypad is locked by pressing (1) "ON" and (4) "DOWN" buttons simultaneously. The display will show the message "Loc" for 1 second.
- The keypad is unlocked by pressing (1) "ON" and (4) "DOWN" buttons simultaneously. The display will show the message "UnL" for 1 second.

SILENCING BEEPER (or AUDIBLE ALARM)

When the beeper is active, press any button to silence the alarm.

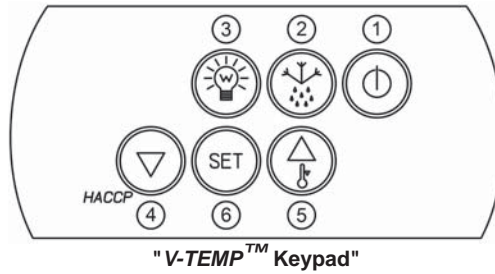

KEYPAD FUNCTIONS (continued)

***Note:** Use "V-TEMP™ Keypad" illustration above to follow these instructions.

SETTING DATE & TIME (*required for all ULTRASPEC™ units)

- a. Press the (4) "DOWN" button for a few seconds, "rtc" will appear on the display.
- b. Press the (6) "SET" button and "yy" for year will appear in the display. Use the "UP" or "DOWN" button to get the correct year.
- c. Hit the "SET" button to lock in the value and to take you to the month value "nn".
- d. Use the "UP" or "DOWN" button to get the correct month and then hit "SET" to lock in this value.
- e. Keep on following the same procedure to set the day "dd", hour "hh", and minute "nn". ***Note:** The hour is based on a 24 hour clock.
- f. After the minute is set, the control will resume normal operation.

SETTING TEMPERATURE SETPOINT

- a. Press the (6) "SET" button and the compressor LED will flash and display will show the current setpoint.
- b. Press the (4) "DOWN" or (5) "UP" button within 15 seconds.
- c. Press the (6) "SET" button to complete the procedure. The Compressor LED will switch off.

***Note:** Setpoint is the cut out temperature. A refrigerator has a 4°F differential; a freezer has a 5°F differential. When a refrigerator is set at 36°F, it will cycle between 36°F and 40°F.

HACCP FUNCTIONS

The control can save up to 9 HACCP alarms after which the most recent alarm will overwrite the oldest.

The control provides the following information:

- > the critical value
- > the date and time when the alarm was activated
- > the alarm duration

CODE	TYPE OF ALARM	CRITICAL VALUE
AL	minimum temp alarm	minimum chamber temperature during this alarm
AH	maximum temp alarm	maximum chamber temperature during this alarm
id	door ajar alarm	maximum chamber temperature during this alarm
PF	power failure alarm	chamber temperature when power is restored

If the duration of the power failure alarm causes a **clock error**, the control will not provide any information regarding the alarm duration. The control has a 48 hour capacitor backup. Any power outage longer than 48 hours may cause a clock error. **If there is a clock error, the time and date must be reset.**

When the cause that activated the alarm event has been resolved, the display restores normal operation except for the power failure alarm. This requires the user to press a button to clear the alarm.

The HACCP LED provides information regarding the memory status of the HACCP alarms. If it is on, not all of the information regarding the HACCP alarms has been displayed. If it flashes, the instrument will have saved at least one new HACCP alarm.

DISPLAYING INFORMATION REGARDING THE HACCP ALARMS

To access the information:

- a. Press the (4) "DOWN" button for 2 seconds: the first label appears on the display.
- b. Use the (5) "UP" or (4) "DOWN" button to select "LS" (List)
- c. Press and release the (6) "SET" button and either of the "AL", "AH", "id", or "PF" codes will appear on the display.
- d. Use the (5) "UP" or (4) "DOWN" buttons to scroll through the alarms and press the (6) "SET" button to display the information pertaining to this alarm.

Note: If the control does not have any alarm saved, the "LS" label will not be displayed.

The information regarding the alarm will appear on the display in sequence. For example, the table below shows how the alarm will be displayed for the "High Temp Alarm" 3rd occurrence.

INFO	MEANING
55	critical value is 55°F
StA	date and time when the alarm was activated is about to appear on the display
y11	alarm was activated year 2011 (continues)
n03	alarm was activated during month of March (continues)
d26	alarm was activated on March 26, 2011
h16	alarm was activated at 16th hour (continues)
n30	alarm was activated at 16:30 hours (continues)
Dur	alarm duration is about to appear on the display
h01	alarm lasted 1 hour (continues)
n15	alarm lasted 1 hour and 15 minutes
AH3	selected alarm; meaning "High Temp Alarm" 3 rd occurrence

To exit from the information sequence:

- a. After the alarm goes through its sequence and the alarm is displayed, AH3 in this example, press and release the (1) "ON/STANDBY" button: "LS" will then be on the display.
- b. Press and release the (1) "ON/STANDBY" button again to go back to the normal display. If no buttons are pressed for 1 minute, the control will also go back to the normal display.

DELETING THE LIST OF HACCP ALARMS

- a. Press and hold the (4) "DOWN" button for 1 second. The display will show "rtc".
- b. Use the "DOWN" button to scroll and select "rLS"
- c. Press and release the (6) "SET" button
- d. Press the (5) "UP" button to scroll and select "149"
- e. Press and release the (6) "SET" button. "- - -" will flash on the display for a few seconds and the HACCP LED will go off and the control will resume normal operation.

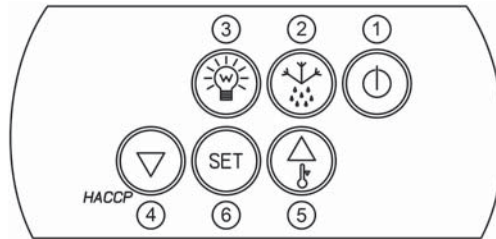

"V-TEMP™ Keypad"

KEYPAD FUNCTIONS (continued)

*Note: Use "V-TEMP™ Keypad" illustration above to follow these instructions.

PARAMETER ACCESS AND ADJUSTMENT

The V-TEMP™ Electronic Control has many parameters the user can adjust to customize the control.

To access the parameters:

- a. Press and simultaneously hold the (5) "UP" button and (4) "DOWN" button for 5 seconds. The first customizable parameter will appear on the display.

- b. To select a parameter to modify use the (5) "UP" button or (4) "DOWN" button to navigate to the parameter you want to change.
- c. Press the (6) "SET" button to go into modify mode.
- d. Use the (5) "UP" or (4) "DOWN" button to select the new parameter value, then press the (6) "SET" button to lock in the value.
- e. You can now navigate to another parameter or you can exit this procedure by pressing the (1) "ON" button for 1 second. This will bring back the normal display.

V-TEMP™ CONTROL ALARM & ERROR CODES

ALARM CODES, DESCRIPTIONS & RESOLUTION(S)

Code	Type of Alarm
AL	Minimum Temperature Alarm
RESOLUTION: (a) Verify cabinet temperature (b) Verify temperature associated with the alarm; see "A1" parameter	
AH	Maximum Temperature Alarm
RESOLUTION: (a) Verify cabinet temperature (b) Verify temperature associated with the alarm; see "A4" parameter	
id	Door Ajar Alarm
RESOLUTION: (a) Make sure door is closed (b) Verify operation of magnetic door switch	
PF	Power Failure Alarm
RESOLUTION: (a) Verify what caused the power failure. Press any button to stop alarm. (b) Verify operation of magnetic door switch	
COH	Condenser Overheat Alarm
RESOLUTION: (a) Verify the condenser temperature. See "C6" parameter. (b) Disconnect power and clean the condenser coil. Check for obstructed air flow over condenser coil.	
dFd	Compressor Overheat Safety Alarm
RESOLUTION: This alarm activates when the defrost terminates on time rather than temperature. (a) Verify that the evaporator probe is intact and in the evaporator coil. (b) Press any button to restore normal display. The unit will continue to function normally.	

Once the cause that activated the alarm is resolved, the control restores normal operation except for the following alarms that require additional intervention:

- 1. "PF" (Power Failure Alarm): press any button to silence alarm
- 2. "CSd" (Compressor Overheat Safety Alarm): the cabinet must be switched "OFF", or disconnect the main power supply

ERROR CODES

Code	Type of Alarm
Pr1	Cabinet Sensor Error
RESOLUTION: The cabinet sensor is located in the return air stream in the evaporator coil housing. (a) Verify the integrity of the sensor. (b) Verify the control sensor connection. *Note: When this error occurs, the control will go into a safe mode. The unit will operate in a pre-programmed ON/OFF cycle.	
Pr2	Evaporator Sensor Error
RESOLUTION: The evaporator sensor is located in the evaporator coil within the evaporator coil housing. (a) Verify the integrity of the sensor. (b) Verify the control-sensor connection. *Note: When this error occurs, the control will go into a safe mode. The defrost will still activate, but operate on a 30 minute timer.	
Pr3	Condenser Sensor Error
RESOLUTION: The condenser sensor is located on the outlet tube of the condenser. (a) Verify the integrity of the sensor. (b) Verify the control-sensor connection. *Note: When this error occurs, there will not be any "COH" or "Csd" alarms.	
rtc	Clock Error
RESOLUTION: (a) The user must reset the date and time. See the section "SETTING DATE AND TIME". *Note: When this error occurs, the control has been without power for over 48 hours.	

Once the cause that activated the error is resolved, the control restores normal operation except for the "rtc" error. This requires the date and time to be set.

USER PARAMETERS

*Refer to the "PARAMETER ACCESS & ADJUSTMENT" section on page 5.

Label	Name	Refrigerator Setting Factory Preset	Freezer Setting Factory Preset	Unit	Minimum	Maximum
Measure Input Configuration Parameters						
CA1	Cabinet probe offset	0	-1	°F	-25	25
This parameter can be used to calibrate the digital display.						
P2	Celsius/Fahrenheit	°F	°F	-	°C (0)	°F (1)
This parameter is used to change the temperature scale.						
Main Regulator Parameters						
r4	ENERGY SAVING setpoint (relative)	2	4	°F	0	99
This parameter is used to set the increase in setpoint when in ENERGY SAVING mode. See also "i10" parameter on next page.						
r5	Overcooling setpoint	5	10	°F	0	99
This parameter is used to set the decrease in setpoint for "SUPER COOL MODE".						
r6	Overcooling timeout	30	30	min	0	240
This parameter is used to set the length of time for "SUPER COOL MODE".						
Compressor Protection Parameters						
C6	Setpoint alarm COH	127	119	°F	0	199
This parameter is used to set the temperature of the COH alarm.						
Defrost Parameters						
d0	Defrost Interval	12	8	h	0	99
This parameter is used to set the defrost interval.						
d8	Kind of Defrost Interval	(0) Time	(0) Time	-	(0) Time	(4) Calendar
This parameter is used to set the type of defrost interval. If real time defrost interval is required, set this to: (4) Calendar. The Hd parameters must be set to the time defrosts are required.						
d20	Max Time for Safety Defrost in Normal Operation	N/A	120	-	0	500
This parameter is used to set the time if the compressor runs constantly so that a defrost will initiate.						
Temperature Alarms Parameters						
A1	Threshold minimum temperature alarm	30	-15	°F	-99	99
This parameter is used to set the threshold for the low temperature alarm.						
A4	Threshold maximum temperature alarm	50	32	°F	-99	99
This parameter is used to set the threshold for the high temperature alarm.						
A7	Alarm Delay	15	15	min	0	240
This parameter is used to set a time delay for the high and low temperature alarms.						
A8	End of Defrost Time Delay	-	30	min	0	240
This parameter is used to set a time delay for the high and low temperature alarms after defrost terminates.						
Evaporator Fan(s) Parameters						
F0	Fans activity during normal operation	(4)THERMO_IF_CMP_ON	N/A	°F	(0) OFF	(5) rhL_rhH
This parameter is used to set the fan speed of the refrigerator evaporator fan(s) in the off cycle of the compressor. The factory preset is to run the fans at low speed during the off-cycle. To set to high speed in the off-cycle, set this parameter to (1) ON						
Digital Inputs Parameters						
i2	Door Alarm Delay	5	5	min	-1	120
This parameter is used to set the time length of door opening that will trigger an "id" alarm (door ajar).						

**Parameters Table continued on next page*

USER PARAMETERS (continued)

*Refer to the "PARAMETER ACCESS & ADJUSTMENT" section on page 5.

Label	Name	Refrigerator Setting Factory Preset	Freezer Setting Factory Preset	Unit	Minimum	Maximum
Digital Inputs Parameters (continued)						
i4	Memo door alarm in HACCP	Yes	Yes	-	No	Yes
This parameter is used to set the type of defrost interval. If real time defrost interval is required, set this to: (4) Calendar. The Hd parameters must be set to the time defrosts are required.						
i10	Time to activate ENERGY SAVING mode by door input	240	240	min	0	999
The parameter is used to set the time length of door inactivity required to initiate the ENERGY SAVING mode. If set to zero, ENERGY SAVING mode will never activate because of door inactivity.						
i13	Number of door openings to start safety defrost	120	120	-	0	240
This parameter is used to set the number of door openings required to initiate a safety defrost. If the normal defrost happens before this number of door openings has accumulated, the counter will be reset back to zero.						
i14	Time of door opening to start safety defrost.	20	20	min	0	240
This parameter is used to initiate a defrost if the door has been open continuously for this amount of time.						
Outputs Configuration Parameters						
u9	Buzzer enabling	Enabled	Enabled	-	Disabled	Enabled
This parameter is used to enable or disable the alarm buzzer. The factory preset is for the buzzer to be active.						
ENERGY SAVING Mode Configuration Parameters						
HE1	ENERGY SAVING mode starting time.	0:00	0:00	-	0:00	23:59
This parameter is used if the user wants to set a time of day the ENERGY SAVING mode activates. See also "HE2".						
HE2	ENERGY SAVING mode duration.	0'	0'	-	0'	23h59'
This parameter is used to set the duration of the ENERGY SAVING mode. See also "HE1".						
Time Bands of Defrost (*optional feature for end-user to program scheduled defrost time periods)						
Hd1	Defrost 1 starting time	---	---	-	0:00	---
Hd2	Defrost 2 starting time	---	---	-	0:00	---
Hd3	Defrost 3 starting time	---	---	-	0:00	---
Hd4	Defrost 4 starting time	---	---	-	0:00	---
Hd5	Defrost 5 starting time	---	---	-	0:00	---
Hd6	Defrost 6 starting time	---	---	-	0:00	---
*Note: These parameters are used to set real time defrosts. Up to 6 defrost times can be programmed. See also "d8" on page 6.						

PERIODIC MAINTENANCE

Cabinet Cleaning

Victory Refrigeration recommends periodic internal and exterior cleaning as outlined below.

Daily Exterior Cleaning

1. Clean the surface with a sponge and cleaning solution. Use a non-abrasive cleaner that does not contain chlorine.
2. Polish with a soft cloth, wiping with the grain of the metal.
3. Once a week wipe with a film cutting agent or stainless steel polish to maintain shine.

Weekly Interior Cleaning

1. Remove all food, food related items and shelves.
2. Discontinue power to the cabinet at the main power supply circuit breaker.
3. Remove loose food particles from the interior floors, walls and ceiling.
4. Scrub all interior surfaces and door gaskets with a warm detergent solution 100°F (38°C) - 120°F (49°C) and a soft nylon bristled brush.
5. Rinse with clear water and allow to air dry.
6. Reinstall the shelves.
7. Return power to the cabinet by resetting main power supply circuit breaker.
8. Return food to the cabinet when temperature indicator reaches safe food temperature.

Condenser Maintenance

To keep your cabinet running efficiently, it is recommended that you clean the condenser coil once every three months or immediately after the "COH" LED displays and alarm activates (*Refer to page 5 "Alarm Codes, Descriptions & Resolutions" Table). However, once a month is recommended if the unit is located near cooking equipment which produces grease laden vapors, i.e. fryers, grills, steam kettles, etc.

1. Discontinue power to the cabinet at the main power supply circuit breaker.
2. Lift hinged front grill to get access to the condenser coil.
3. Use a vacuum cleaner with proper brush attachments to clean the condenser coil, compressor-motor and related parts.
4. In extreme cases of dust and grease buildup, the condenser coil fins may require blowing out with compressed air or cleaning with a de-greasing agent.
5. Return power to cabinet by resetting main power supply circuit breaker.

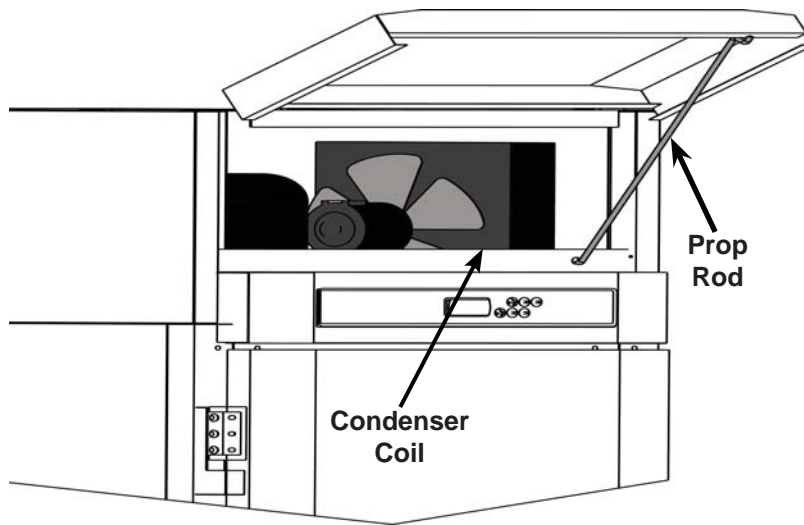

"Top of Refrigerator/Freezer Cabinet with Raised Grill Assembly"

WARNING: Failure to keep the condenser coil clean may cause premature failure of the compressor-motor which will NOT be covered by warranty.

Lubrication

Unless otherwise specified, all Victory refrigerators and freezers are equipped with permanently lubricated motors. The compressor-motor is a sealed unit and is constantly lubricated when in operation. The condenser and evaporator fan motors are also equipped with lubricated bearings which never need to be oiled.

Installing Replacement Door Gasket (if required)

Removing

Beginning at one corner, pry the gasket loose from the retaining strip. Peel remainder of the gasket from the door and discard.

Replacing

Before replacing, be sure the gasket and door are at room temperature. (If necessary, soak the gasket in warm water to make it more pliable.) Align the new gasket frame on the door retainer strip. Starting at one corner, press each corner of the gasket into the retainer strip. Once started, the gasket can be easily inserted around the entire perimeter of the door by simply press rolling into place.

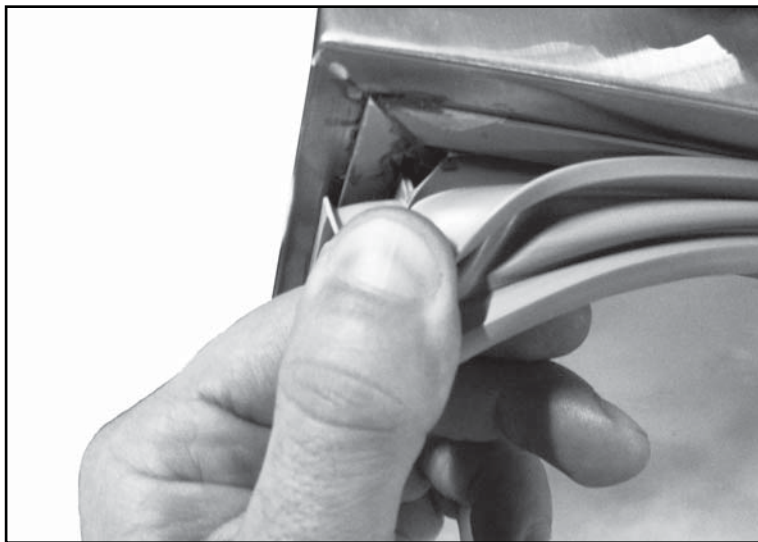

Door Gasket & Retainer Strip

TROUBLESHOOTING GUIDE FOR COMMON PROBLEMS

Caution: Disconnect Power Supply Prior To Attempting Any Service!

PROBLEM	POSSIBLE CAUSE	REMEDY
Controller Display does not illuminate	Fuse blown or circuit breaker tripped	Replace fuse or reset circuit breaker
	Power cord unplugged	Plug in power cord to designated receptacle. Cabinet cannot share same outlet with other equipment.
	Control or main power switch turned off	Turn on control or main power switch (refer to page 3 "V-TEMP™ Keypad Buttons & Functions" section)
Cabinet not running	Improper voltage supplied to cabinet (voltage does not match Data-Plate)	Correct supply voltage (remove extension cords or other equipment on circuit, etc).
	Controller set too high	Set controller to lower temperature
	Cabinet in defrost cycle	Allow defrost cycle to finish
Condensing Unit on Refrigerator or Freezer runs for prolonged period or continuously	Excessive amount of warm product loaded in cabinet	Allow adequate time for product to cool down
	No product in cabinet	Load cabinet with product
	Prolonged door opening or door ajar	Make sure door is closed when not in use. Avoid prolonged door openings.
	Door gasket not sealing properly	Check door gasket condition. Adjust door or replace gasket.
	Dirty condenser coil	Clean the condenser coil
	Improper air flow around condensing unit	Insure adequate air space, relocate away from heat generating equipment, direct sunlight, or direct path of air conditioning or heating ducts
	Evaporator coil blocked with ice	Turn unit off and allow coil to defrost. Make sure controller temperature is not set too low and that door gasket is sealing properly.
Refrigerator or Freezer cabinet temperature too high	Controller set too high	Set controller to lower temperature
	Poor air circulation in cabinet	Re-arrange product to allow proper air circulation
	Excessive amount of warm product loaded in cabinet	Allow adequate time for product to cool down
	Prolonged door opening or door ajar	Make sure door is closed when not in use. Avoid prolonged door openings.
	Dirty condenser coil	Clean the condenser coil
	Insufficient clearance around cabinet or excessively high ambient temperature	Insure adequate air space, relocate away from heat generating equipment (ovens, fryers, heating ducts, etc.), and out of direct sunlight
	Evaporator coil blocked with ice	Turn unit off and allow coil to defrost. Make sure controller is not set too cold and that door gasket is sealing properly.
Cabinet is noisy	Part(s) loose	Locate and tighten loose part(s)
	Tubing vibrating	Insure tubing is free from contact with other tubing or components
Refrigerator is freezing product	Controller set too low	Set controller to higher temperature
	Cabinet overloaded with product	Remove or re-arrange product
Refrigerator or Freezer compressor will not start - hums and trips on overload protector	Dirty condenser coil	Clean the condenser coil
	Excessive heat generated from nearby equipment	Relocate cabinet or adjust heat generating equipment
	Voltage to cabinet too high or too low	Check and correct supply voltage
Door won't close tight	Cabinet is not level	Level cabinet by adjusting legs or shimming casters
	Hinge(s) may need slight adjusting.	Apply shim(s) to hinge until door seals properly.
Controller Alarm & Error Codes	----	Refer to page 5 of manual. If problem(s) persist, contact the factory for further assistance.

WIRING DIAGRAMS

1 & 2 Section Refrigerator Wiring Diagram for 115 Volt/15 Amp & 20 Amp

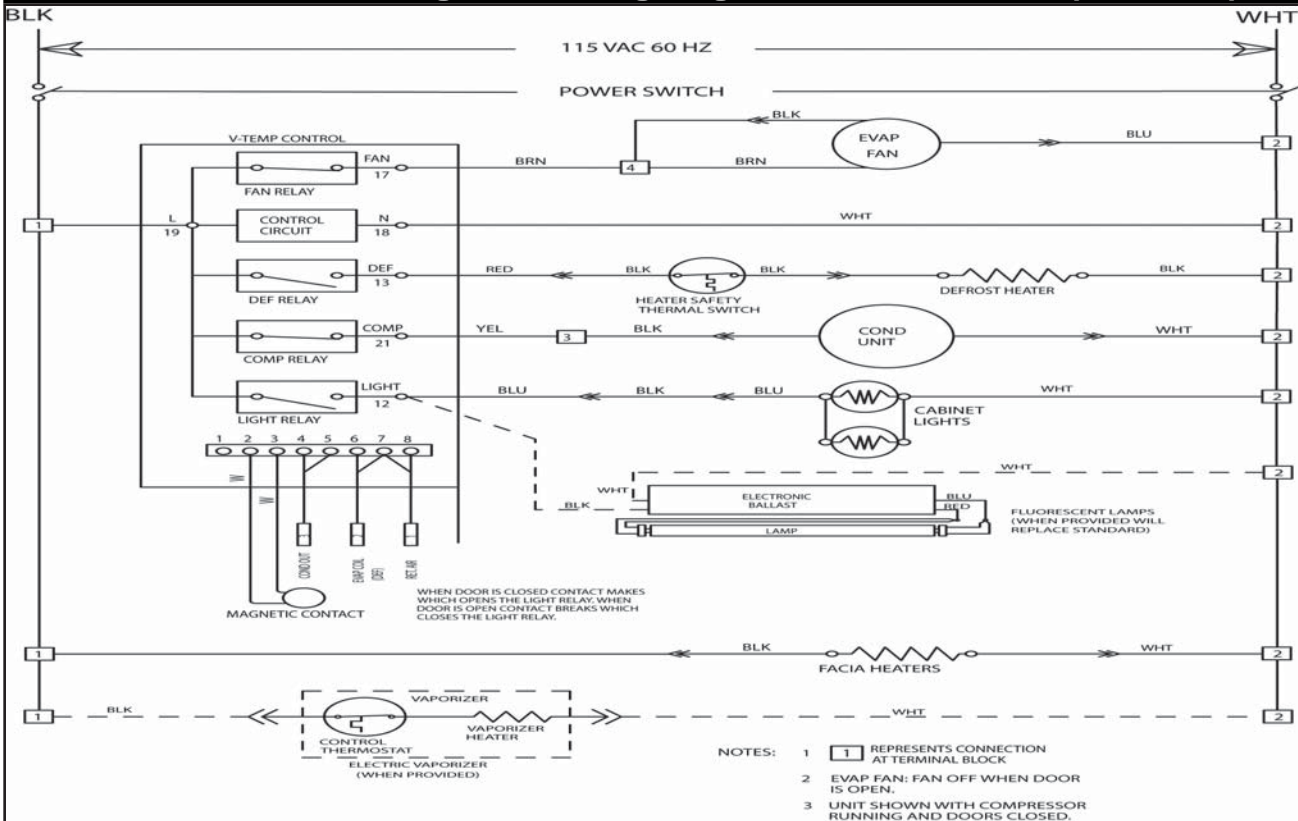

3 Section Refrigerator Wiring Diagram for 115 Volt/208-230 Volt Condensing Unit

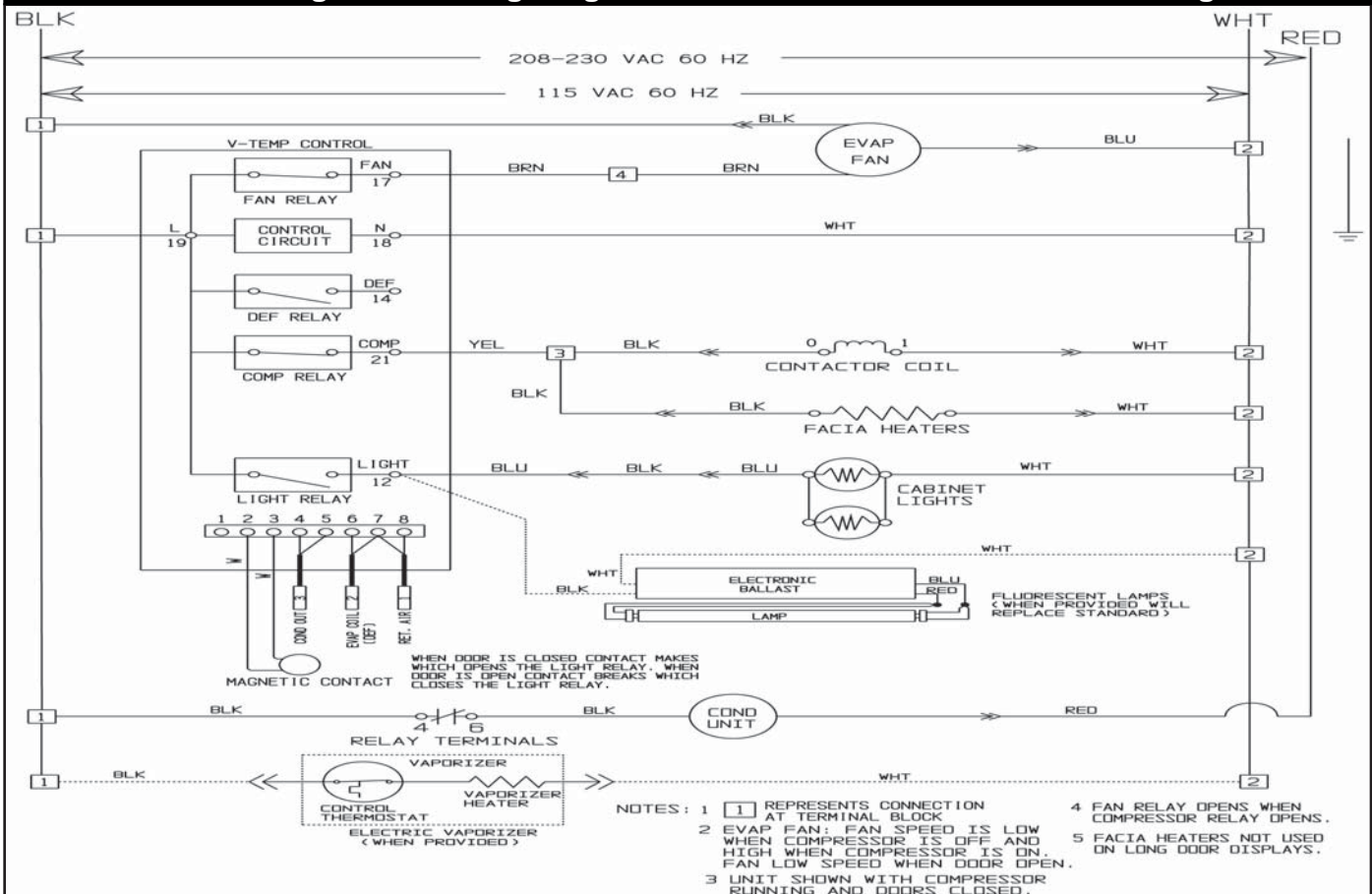

1, 2 & 3 Section Freezer Wiring Diagram for 115 Volt/15 Amp & 20 Amp

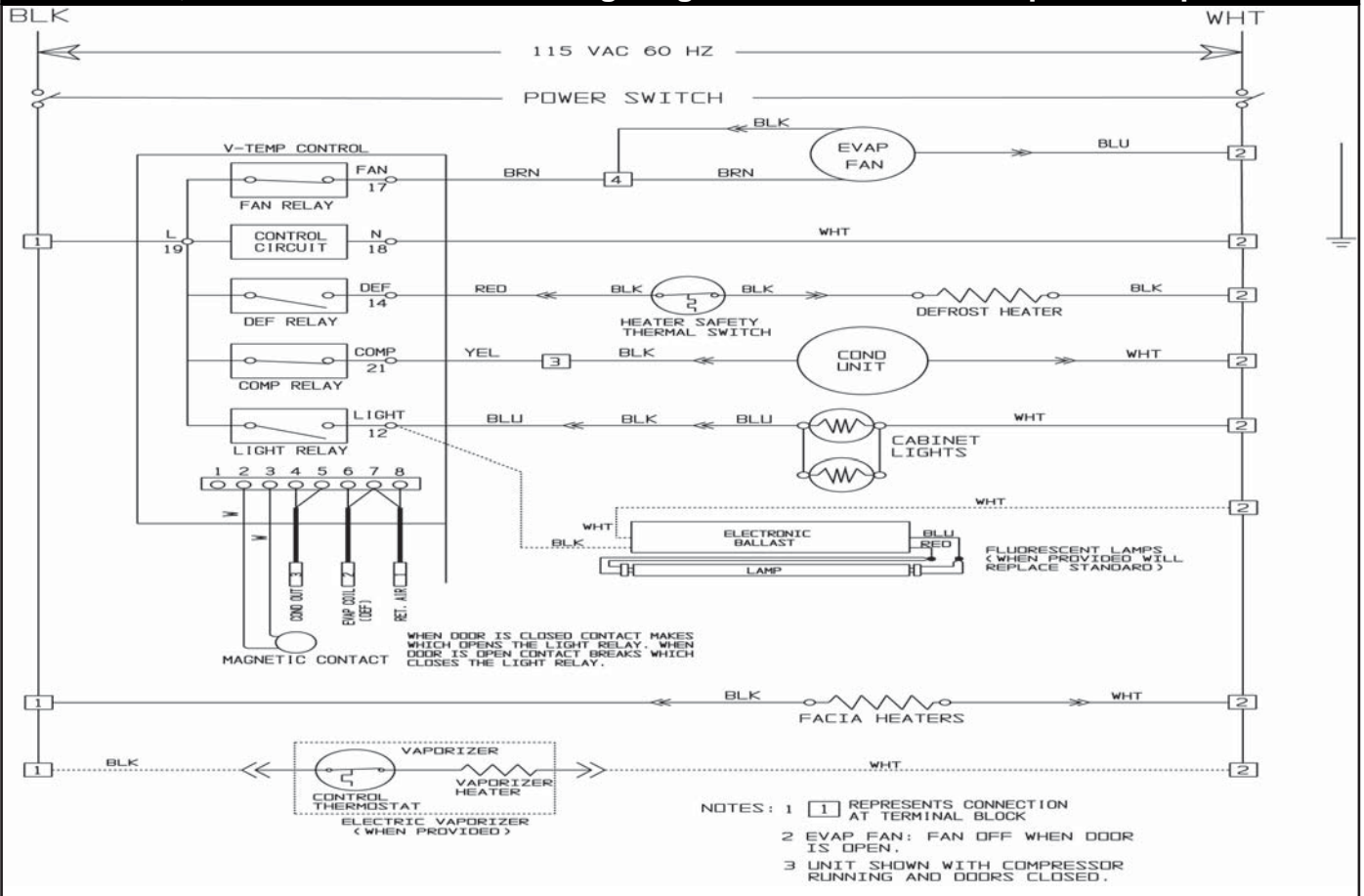

1, 2 & 3 Section Freezer Wiring Diagram for 115 Volt/208-230 Volt Condensing Unit

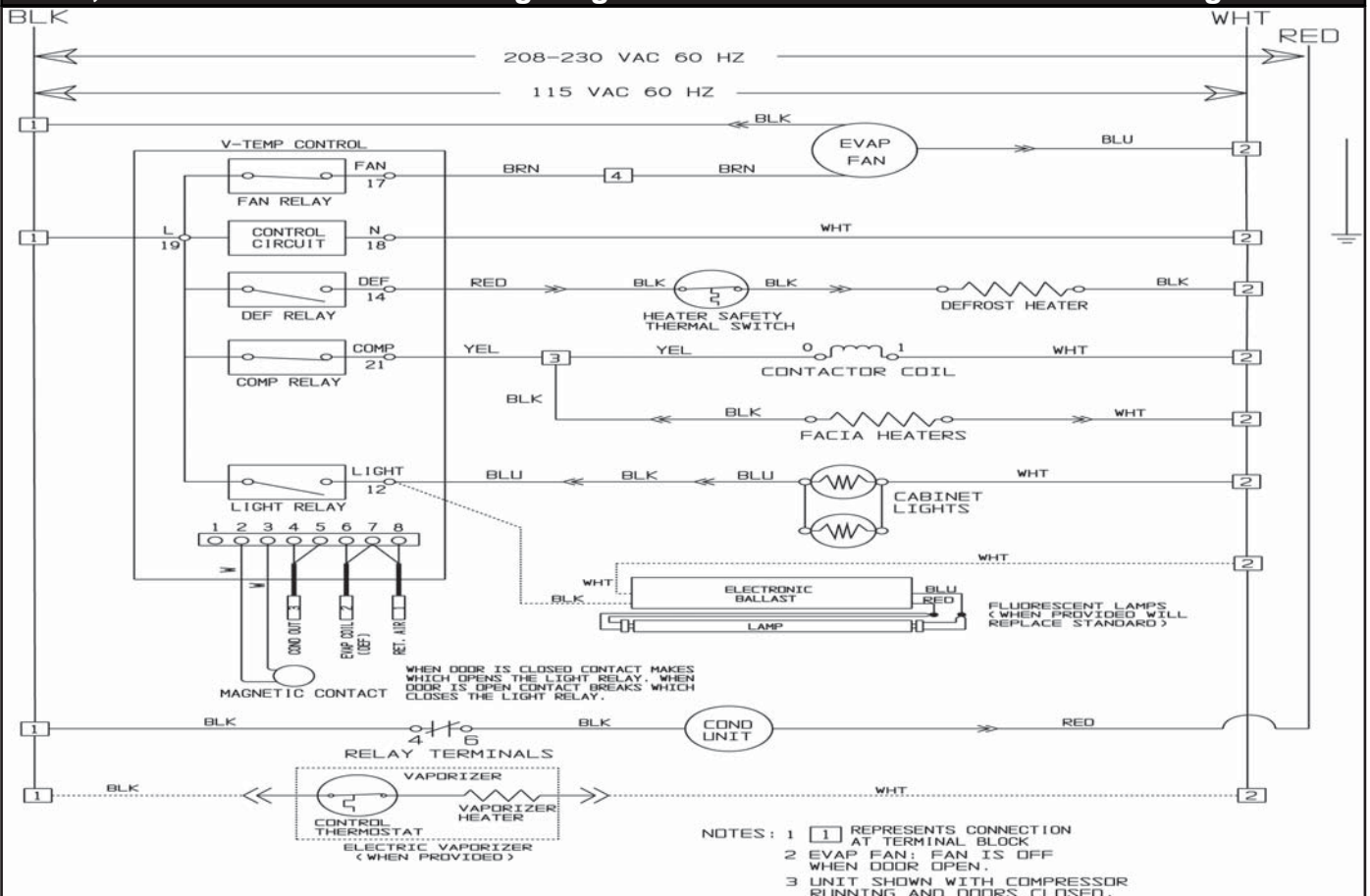



110 Woodcrest Road, Cherry Hill, NJ 08003

Phone: (856) 428-4200 Fax: (856) 673-0038 Website: www.victoryrefrigeration.com

E-Mail: parts@victoryrefrigeration.com order-entry@victoryrefrigeration.com service@victoryrefrigeration.com