



AIR CURTAIN REFRIGERATOR

Model ACRS-ID-S-STS

Self Contained-Bottom Mounted System

Congratulations on becoming the owner of a new Air Curtain refrigerator. This bottom mounted mobile refrigerator is ideal for tray assembly lines in hospitals, flight kitchens, cafeterias, fast food operations or any meal tray assembly operation.

STANDARD FEATURES:

- Exterior Temperature Sensing Dial
- Removable Stainless Steel Pan Slides
- Condensate Automatically Evaporated
- Plasticized Fin Coil
- Stainless Steel Case Back
- Rear Mounted Push Bar Handle with Rubber Bumpers
- Stainless Steel Hinges
- Full 270 Degree Door Swing
- 6 inch Diameter Heavy Duty Casters with Wheel Locks
- Heavy-Duty Cylinder Lock
- Self-Adjusting Magnetic Gaskets
- Cord and Plug Attached
- Flush Recessed Side Hand Grips

CABINETS:

All metal construction with joints and seams completely closed and sealed. The case front, door.

The case is internally supported, braced and assembled into a single rigid unit construction. All inside corner bends are rounded to a ¼ inch radius for ease of cleaning and to conform to National Sanitation Foundation codes.

OPERATION:

When the door is shut the cabinet operates as a standard refrigerator for normal temperature storage. The cabinet is designed with air ducts on the left and right side of the interior. Each air duct has a series of strategically placed holes for proper air flow. When the door is opened, a curtain of cold air blows across the cabinet opening from left to right. This keeps hot air out and cold air in, assuring safe storage during peak service time. This is accomplished by means of three blower fans and motors that are activated by the door switch. This action triples the air velocity in the product zone.

It is recommended that the door be left open a maximum time of 45 minutes.

The actual time will depend on ambient temperatures, product temperatures, packaging and other factors. The cabinet is designed primarily for low profile product such as salads, pudding, desserts, milk, etc. Do not place large pans or containers inside that will block or hamper the air flow and the overall performance of the cabinet.

If the door is left open for a period of longer than one hour, the ambient temperature will rise, however the product temperature will lag considerably. The differential in ambient to product temperature could be as much as 15 degrees F.

The Air Curtain cabinet has a 20 amp cord and plug attached. The cabinet has a NEMA Plug 5-20-P and requires a NEMA 5-20-R receptacle

INTERIOR TEMPERATURE CONTROL:

Your Air Curtain has been preset at the factory and should not require any additional adjustment. However, if adjustment is necessary, locate the temperature control at the rear access panel. There are two adjustment screws on the control. **TURN THE LOWER SCREW ONLY!** Clockwise for colder interior temperatures, counter-clockwise for a warmer temperature.

The upper (cut-in) screw has been preset for defrosting the coil and should not be reset unless by a qualified refrigerator service company.

NOTE: Your Air Curtain is equipped with an electric condensate vaporizer. Excess condensate water flows from the evaporator cooling coil, down a drain tube in the back of the cabinet, to the vaporizer located in the bottom.

When this cold water enters the vaporizer, a thermostat is activated and the water is boiled off. The resulting steam is vented by an aluminum elbow and vapor may be seen at the bottom and/or front of the unit. This is part of

normal operating procedure for the condensate disposal system.

All the water in the vaporizer should be allowed to boil off after the unit has finished operation for the day to avoid possible overflow.

PAN SLIDES:

There are 15 sets of removable pan slides provided with the STS model. These are designed to bottom support 18 X 26 inch pans and are easily removable, no tools are required. The slides are attached by means of key hole slots to the air distribution ducts on 3/4 inch centers for maximum air circulation. The ducts may also be removed for cleaning by turning the thumb screws counter clockwise.

MOVING THE CABINET:

Even though the cabinet weighs 320 pounds, it is easy to maneuver when in use. This is accomplished by the use of recessed side hand grips, a push bar handle with rubber bumpers and heavy duty non-mar casters.

Since the condensing unit is located in the base of the cabinet, there is a low center of gravity making it more stable when transporting and the operator has easy access to all pans at a comfortable working height.

CLEANING/MAINTENANCE:

A program of preventive maintenance must be established to keep your Air Curtain Refrigerator functioning efficiently. Therefore, it is necessary to keep the cabinet clean and properly serviced. Door swings open a 270 degree angle to allow full access into the interior cabinet for cleaning.

Proper Detergent Use: As sanitation codes vary, it is important to follow the requirements of local health authorities.

Use a detergent-sanitizer or a mild detergent (neutral or mildly alkaline recommended for metal surfaces) followed by a sanitizing rinse solution. Sanitizing chemicals are necessary to kill or deactivate the micro-organisms on the surface areas in contact with stored food. Choose these chemicals carefully. Some are toxic and should only be used on non-food surfaces.

Quats (quaternary ammonium) are usually the best sanitizing compounds, for they are relatively non-corrosive and have better detergent and deodorizing properties than chlorine or iodine compounds. When using these products, it is important to follow label directions exactly to obtain the correct sanitizing action.

Recommended Cleaning Procedures: Interior cleaning recommended to maintain good sanitary conditions and to eliminate odors.

Avoid excessive use of water during cleaning activities.

CAUTION — PRIOR TO ANY CLEANING OPERATION, DISCONNECT POWER CORD FROM RECEPTACLE.

Interior Surface Cleaning:

1. Remove all food, trays and pan slides from cabinet and disconnect power cord from receptacle.
2. Open door and allow room air to enter cabinet. When temperature of storage compartment approximates room temperature, remove all loose food particles.
3. With a nylon bristle brush, scrub all interior surfaces with a warm detergent solution (100-120 degree F.).
4. Rinse with clear warm water using a non-woven disposable cloth. Remove excess rinse water with a cloth.
5. Wipe all interior surfaces with a sanitizing solution and allow to air dry. Return pan slides to unit.

IMPORTANT — DO NOT CLEAN WITH STEAM OR SPRAY TYPE CLEANING MECHANISMS. THESE CLEANING TOOLS CAN DAMAGE THE REFRIGERATOR UNIT.

Exterior Surface Cleaning:

Cleaning and sanitizing agents for stainless steel exterior should be used daily.

1. Dip non-woven disposable cloths in cleaning solution, wipe down metal surfaces and allow to air dry.
2. Spray surfaces with stainless steel polish or wipe down with lemon oil. Polish with a clean soft cloth.
3. Once a week a film cutting agent may be used for metal finishes to maintain surface shine.

Condenser Maintenance:

The condensing unit is located at the bottom rear of the cabinet. Monthly cleaning is necessary to keep the required amount of air passing through the condenser and maintain operating efficiency.

1. Disconnect the electrical service cord from the receptacles.
2. Use a vacuum cleaner with proper brush attachments, a stiff brush or a whisk broom to clean the compressor motor and related parts. In extreme cases of dust and grease buildup, the condenser fins may require blowing out with compressed air or freon.

TROUBLE SHOOTING & SERVICING REFRIGERATION SYSTEM

PROBLEM	POSSIBLE CAUSE	REMEDY
1. Condensing unit fails to start — no hum	<ol style="list-style-type: none"> 1. Line disconnected switch open. 2. Fuse removed or blown 3. Overload protector tripped 4. Control stuck in open position. 5. Wiring improper or loose. 	<ol style="list-style-type: none"> 1. Close start or disconnect switch 2. Replace fuse 3. Determine reason and correct. replace if necessary. 4. Repair or replace control. 5. Check wiring against diagram.
2. Condensing unit fails to start — hums but trips on overload protector.	<ol style="list-style-type: none"> 1. Improperly wired. 2. Low voltage to unit. 3. Starting capacitor defective. 4. Relay failing to close. 5. Compressor motor has a winding open or shorted. 6. Internal mechanical trouble in compressor. 	<ol style="list-style-type: none"> 1. Check wiring against diagram. 2. Determine reason and correct. 3. Determine reason and replace. 4. Determine reason and correct. replace if necessary. 5. Replace compressor. 6. Replace compressor.
3. Condensing unit starts, but fails to switch off of "start" winding.	<ol style="list-style-type: none"> 1. Improperly wired. 2. Low voltage to unit. 3. Relay failing to open. 4. Run capacitor defective. 5. Excessively high discharge pressure. 6. Compressor motor has a winding open or shorted. 7. Internal mechanical trouble in compressor. 	<ol style="list-style-type: none"> 1. Check wiring against diagram. 2. Determine reason and correct. 3. Determine reason and correct. replace if necessary. 4. Determine reason and replace. 5. Check discharge shut-off valve. possible overcharge, or insufficient cooling on condenser. 6. Replace compressor. 7. Replace compressor.
4. Condensing unit starts and runs, but short cycles on overload protector.	<ol style="list-style-type: none"> 1. Additional current passing through overload protector. 2. Low voltage to unit (or unbalanced if three phase). 3. Overload protector defective. 4. Run capacitor defective. 5. Excessive discharge pressure. 6. Suction pressure too high. 7. Compressor too hot — return gas. 8. Compressor motor has a winding shorted. 	<ol style="list-style-type: none"> 1. Check wiring diagram. Check for added fan motors, pumps, etc. connected to wrong side of protector. 2. Determine reason and correct. 3. Check current, replace protector. 4. Determine reason and replace. 5. Check ventilation, restrictions in cooling medium, restrictions in refrigeration system. 6. Check for possibility of mis-application. Use stronger unit. 7. Check refrigerant charge (fix leak) add if necessary. 8. Replace compressor.
5. Condensing unit runs but short cycles on . . .	<ol style="list-style-type: none"> 1. Overload protector. 2. Thermostat. 3. High pressure cut-out due to: <ol style="list-style-type: none"> a. insufficient air or water supply. b. overcharge. c. air in system. 4. Low pressure cut-out due to: <ol style="list-style-type: none"> a. Liquid line solenoid leaking. b. Compressor valve leak. c. Undercharge. d. Restriction in expansion device. 	<ol style="list-style-type: none"> 1. See (4) above. 2. Differential set too close — widen. 3a. Check air or water supply to condenser - correct. 3b. Reduce refrigerant charge. 3c. Purge. 4a. Replace. 4b. Replace. 4c. Fix leak, add refrigerant. 4d. Replace device.

PROBLEM	POSSIBLE CAUSE	REMEDY
6. Condensing unit operates for prolonged periods or continuously.	<ol style="list-style-type: none"> 1. Shortage of refrigerant. 2. Control contacts stuck or frozen closed. 3. Excessive heat load placed into cabinet. 4. Prolonged or too frequent door openings. 5. Evaporator coil iced. 6. Restriction in refrigeration system. 7. Dirty condenser. 8. Filter dirty. 	<ol style="list-style-type: none"> 1. Fix leak, add charge. 2. Clean contacts or replace control. 3. Allow unit sufficient time for removal of latent heat. 4. Plan or organize schedule to correct condition. 5. Defrost. 6. Determine location and remove. 7. Clean condenser. 8. Clean or replace.
7. Start capacitor open or shorted or blown.	<ol style="list-style-type: none"> 1. Relay contacts not opening properly. 2. Prolonged operation on start cycle due to: <ol style="list-style-type: none"> a. Low voltage to unit. b. Improper relay. c. Starting load too high. 3. Excessive short cycling. 4. Improper capacitor. 	<ol style="list-style-type: none"> 1. Clean contacts or replace relay if necessary. 2a. Determine reason and correct. 2b. Replace. 2c. Correct by using pump down arrangement if necessary. 3. Determine reason for short cycling (see 5 above) and correct. 4. Determine correct size and replace.
8. Run capacitor open, shorted or blown.	<ol style="list-style-type: none"> 1. Improper capacitor. 2. Excessively high line voltage (110% of rated-max.) 	<ol style="list-style-type: none"> 1. Determine correct size and replace. 2. Determine reason and correct.
9. Relay defective or burned out.	<ol style="list-style-type: none"> 1. Incorrect relay. 2. Incorrect mounting angle. 3. Line voltage too high or too low. 4. Excessive short cycling. 5. Relay being influenced by loose vibrating mounting. 6. Incorrect run capacitor. 	<ol style="list-style-type: none"> 1. Check and replace. 2. Remount relay in correct position. 3. Determine reason and correct. 4. Determine reason (see 5 above) and correct. 5. Remount rigidly. 6. Replace with proper capacitor.
10. Product zone temperature too high.	<ol style="list-style-type: none"> 1. Control setting too high. 2. Inadequate air circulation. 	<ol style="list-style-type: none"> 1. Reset control. 2. Rearrange product load to improve air circulation.
11. Suction line frosted or sweating.	<ol style="list-style-type: none"> 1. Overcharge of refrigerant. 2. Evaporator fan not running. 3. If remote model, expansion valve stuck open. 4. If remote model, expansion valve passing excess refrigerant or is oversized. 	<ol style="list-style-type: none"> 1. Correct charge. 2. Determine reason and correct. 3. Clean valve of foreign particles, replace if necessary. 4. Readjust valve or replace with smaller valve.
12. Liquid line frosted or sweating.	<ol style="list-style-type: none"> 1. Restriction in dehydrator or strainer. 2. Liquid shut-off (king valve) partially closed. 	<ol style="list-style-type: none"> 1. Replace part. 2. Open valve fully.
13. Noisy Condensing unit.	<ol style="list-style-type: none"> 1. Loose parts or mountings. 2. Tubing rattle. 3. Bent fan blade causing vibration 4. Fan motor bearings worn. 	<ol style="list-style-type: none"> 1. Find and tighten 2. Reform to be free of contact. 3. Replace blade. 4. Replace motor.

REPLACEMENT PARTS LIST



AIR CURTAIN REFRIGERATOR

Model ACRS-ID-S-STS

Self Contained-Bottom Mounted System

REFRIGERATION COMPONENTS

<u>Part No.</u>	<u>Description</u>
50181401	TEMPERATURE CONTROL, 3 ft. cap tube (Mounted at top of cabinet)
50181402	TEMPERATURE CONTROL, RANCO 6 ft. cap tube (Mounted on the bottom)
50156801	COIL, Evaporator finned, 66F20
10490001	COIL ASSEMBLY (Consists of Coil and Heat Exchanger)
50633501	COMPRESSOR, AJ7441A, 1/2 HP
10477111	DRAIN PAN ASSEMBLY
50199101	CAPILLARY TUBES, .049 x 10' (2 required)
44103001	HEAT EXCHANGER ASSEMBLY (Consists of cap tube and suction line with flared fitting)
50184101	ACCUMULATOR, Suction Line 1/4"
50369501	CRANKCASE VALVE
50183802	FILTER DRYER
50647001	CONDENSER COIL

ELECTRICAL ITEMS

50193101	MOTOR, Condenser Fan 9W
50639801	MOTOR, Evaporator fan 115V (04096601 mounting bracket)
50580101	BLADE, Evaporator fan, 6" 4 blade plastic
50618701	BLADE, Condensor fan, 8-3/4" CW AL
50618401	FAN BRACKET (Condenser) 115V
50595001	HEATER WIRE, Door frame 115V (Blue and White leads)
50584001	SWITCH, Toggle, DPST 20 Amp
10490503	VAPORIZER ASSEMBLY 115V, 300 WT
50190901	VAPORIZER, Thermostat, Bi-metal 3/4" diameter
50584201	CORD & PLUG, 115V 20 Amp
50357501	SWITCH, Door, Plunger type
WD628A	WIRING DIAGRAM
10477011	FAN PANEL ASSEMBLY (w/ Motors, Blades and Brackets)
10489801	POWER HARNESS (Cabinet)

DOORS & COMPONENT PARTS

10583402 DOOR ASSEMBLY COMPLETE, Right Hand Hinge, S/S handle
10583401 DOOR ASSEMBLY COMPLETE, Left Hand Hinge, S/S handle
50674101 DOOR, Glass, Left Hand Hinge (Early style lock located above handle)
50674102 DOOR, Glass, Right Hand Hinge (Early style lock located above handle)
50682302 DOOR, Glass, Left Hand Hinge (Late style lock located in center of handle)
50682301 DOOR, Glass, Right Hand Hinge (Late style lock located in center of handle)
50582903 GASKET, Magnetic 53-3/8" x 25-9/16"
50677001 GASKET, Glass door
50594801 RETAINER, Gasket Top and Bottom 24-3/4" long
50594802 RETAINER, Gasket Sides 52-17/32" long
50615901 DOOR HANDLE, Glass door (chrome)
50583701 DOOR HANDLE, Black (Obsolete)
50673901 DOOR HANDLE, S/S (Current Style)
50575301 HINGE ASSEMBLY, Right Hand
50575302 HINGE ASSEMBLY, Left Hand
50190701 LOCK, Cylinder type - Key XC-3 (Key Part # 50190702)
50597107 LOCK, Cylinder type - Key #312 (Key Part # 50597108)

CABINET HARDWARE, ACCESSORIES & MISCELLANEOUS ITEMS

50575006 POLY WHEEL 6" (Rigid Caster) Back
50575005 POLY WHEEL 6" (Swivel Caster) Front w/brake
10490302 CASTER MOUNTING ASSEMBLY
10601101 PAN SLIDE ASSEMBLY (2 required for 1 pair)
50268601 SHELF 18" x 25" (Optional, used only in lieu of Sheet Pan.)
50598102 KEEPER, Door lock
10501201 PUSH HANDLE ASSEMBLY
50571801 PUSH HANDLE BUMPER (Doughnut)
05107001 HOLDER, Door open (includes thumb screw & washer)
50672001 SIDE PULL HANDLE
50683201 THERMOMETER, Dial
50395101 THERMOMETER, Dial type
50602301 DIGITAL THERMOMETER, round
50679701 BUMPER GUARD, Grey rubber 30-3/4" (sides)
50679702 BUMPER GUARD, Grey rubber 27-1/16" (front & rear)
50373405 TRIM, Snap top and bottom, gray plastic (21-1/16" long)
50373406 TRIM, Snap sides, gray plastic (47-3/16" long)
50373602 TRIM, Corner, gray
50382201 MASONITE, Top and Bottom
50594901 MASONITE, Side
05098501 FRONT GRILL
09137401 REAR GRILL
06111104 FRONT COIL ENCLOSURE PANEL
50736401 VICTORY LOGO (7)
06111303 FAN PANEL

AIR CURTAIN REFRIGERATOR WIRING DIAGRAM

WD-628A

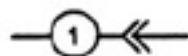
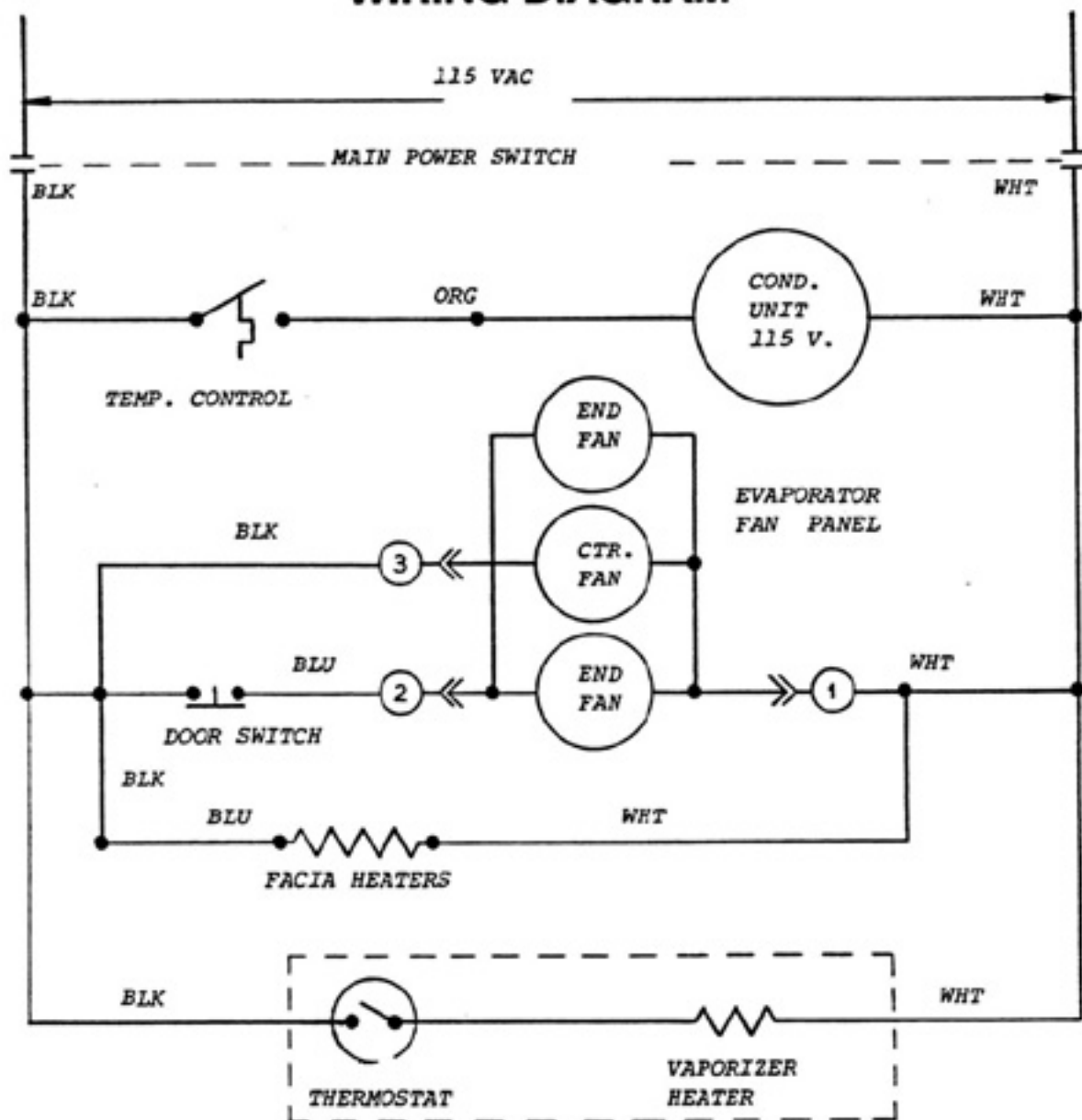

MULTI-PIN
DISC. TERM.

WD-628A

Sep. 1982

Warranty

(Continental USA Only)

The Seller warrants to the original purchaser, equipment manufactured by Seller to be free from defects in material and workmanship for which it is responsible. The Seller's obligation under this warranty shall be limited to replacing or repairing at Seller's option, without charge, F.O.B. Seller's factory, any part found to be defective and any labor and material expense incurred by Seller in repairing or replacing such part, such warranty to be limited to a period of one year from date of purchase or thirteen months from date of shipment from Seller's factory, whichever is earlier, provided terms of payment have been fully met. All labor shall be performed during regular working hours. Overtime premium charges will be at Buyer's expense.

Proof of purchase must be supplied to Seller to validate warranty. This warranty is valid only if equipment is properly installed, started-up and inspected by the dealer or authorized Victory Service agent.

Removal or alteration of the serial/data plate from any equipment shall be deemed to release Seller from all warranty obligations or any other obligations, expressed or implied.

This warranty does not cover Thermostat or Defrost Timer calibration and/or adjustment, freight damage, normal maintenance items outlined in Owner's Manual, adjustment of door mechanisms or replacement of light bulbs, fuses or batteries.

Any repairs or replacement of defective parts shall be performed by Seller's authorized service personnel. Seller shall not be responsible for any costs incurred if the work is performed by other than Seller's authorized service personnel. Reimbursement claims for part(s) or labor service costs must be made in writing. Model, cabinet serial numbers and installation location must be shown on the claim. A receipted bill from the servicing agency must accompany the claim, together with full details of the service problems, diagnosis and work performed. Victory reserves sole discretion whether further documentation on a claim is to be submitted.

Seller shall not be liable for consequential damages of any kind which occur during the course of installation of equipment, or which result from the use or misuse by Buyer, its employees or others of the equipment supplied hereunder, and Buyer's sole and exclusive remedy against Seller for any breach of the foregoing warranty or otherwise shall be for the repair or replacement of the equipment or parts thereof affected by such breach.

The foregoing warranty shall be valid and binding upon Seller if and only if Buyer loads, operates and maintains the equipment supplied hereunder in accordance with the instruction manual provided to Buyer. Seller does not guarantee the process of manufacture by Buyer or the quality of product to be produced by the equipment supplied hereunder and Seller shall not be liable for any prospective or lost product or profits of Buyer.

THE FOREGOING WARRANTY IS EXCLUSIVE AND IN LIEU OF ALL OTHER EXPRESS AND IMPLIED WARRANTIES WHATSOEVER. SPECIFICALLY THERE ARE NO IMPLIED WARRANTIES OF MERCHANTABILITY OR OF FITNESS FOR A PARTICULAR PURPOSE.

The foregoing shall be Seller's sole and exclusive obligation and Buyer's sole and exclusive remedy for any action, whether in breach of contract or negligence. In no event shall Seller be liable for a sum in excess of the purchase price of the item.

You may register online at www.victory-refrig.com, fax this completed page to (856) 428-7299, or copy and mail form below to Victory.

*NOTE: The following mail-in form or online registration must be filled out and forwarded to Victory by the installer or customer within 10 days after start-up. Failure to do this will invalidate the warranties. Retain this information for your records.



110 WOODCREST ROAD
CHERRY HILL, NJ 08003-3648
TEL: (856) 428-4200 • FAX: (856) 428-7299

Cabinet Model No. _____

Cabinet Serial No. _____

(Data plate information located inside cooler on the upper left wall)

**WARRANTIES NOT VALID UNLESS REGISTERED AT
FACTORY WITHIN 10 DAYS AFTER START-UP DATE.**

ORIGINAL DATE OF INSTALLATION _____

INSTALLATION COMPANY NAME _____

STREET _____ CITY _____ STATE _____ ZIP CODE _____

DISTRIBUTOR'S NAME _____

STREET _____ CITY _____ STATE _____ ZIP CODE _____

We reserve the right to change specifications and product design without notice. Such revisions do not entitle the buyer to corresponding changes, improvements, additions or replacements for previously purchased equipment.



P.O. Box 507
Cherry Hill, NJ 08003
(609) 428-4200 • FAX: (609) 428-7299

Operations Manual
Part Number 50643601
Price \$5.00
R3/96